

OGANESÓN

ON STAGE 26

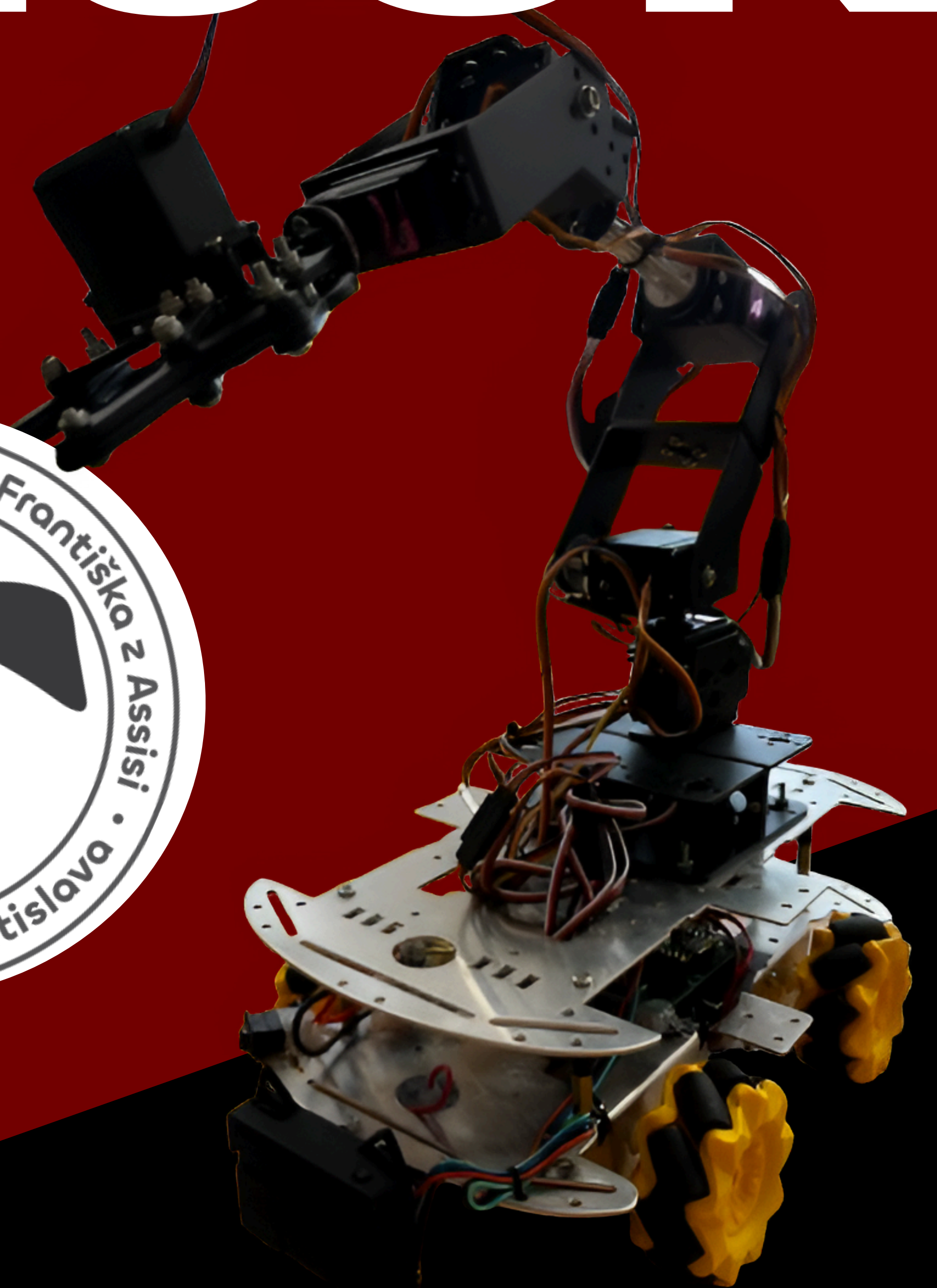

Part list

All three robots have:

chassis with 4 mecanum wheels, each driven by its own motor

Lidar Coin D6

2pcs Lilon 3.8V 186500 batteries and plastic holders for 18650

power supply 5V (8A)

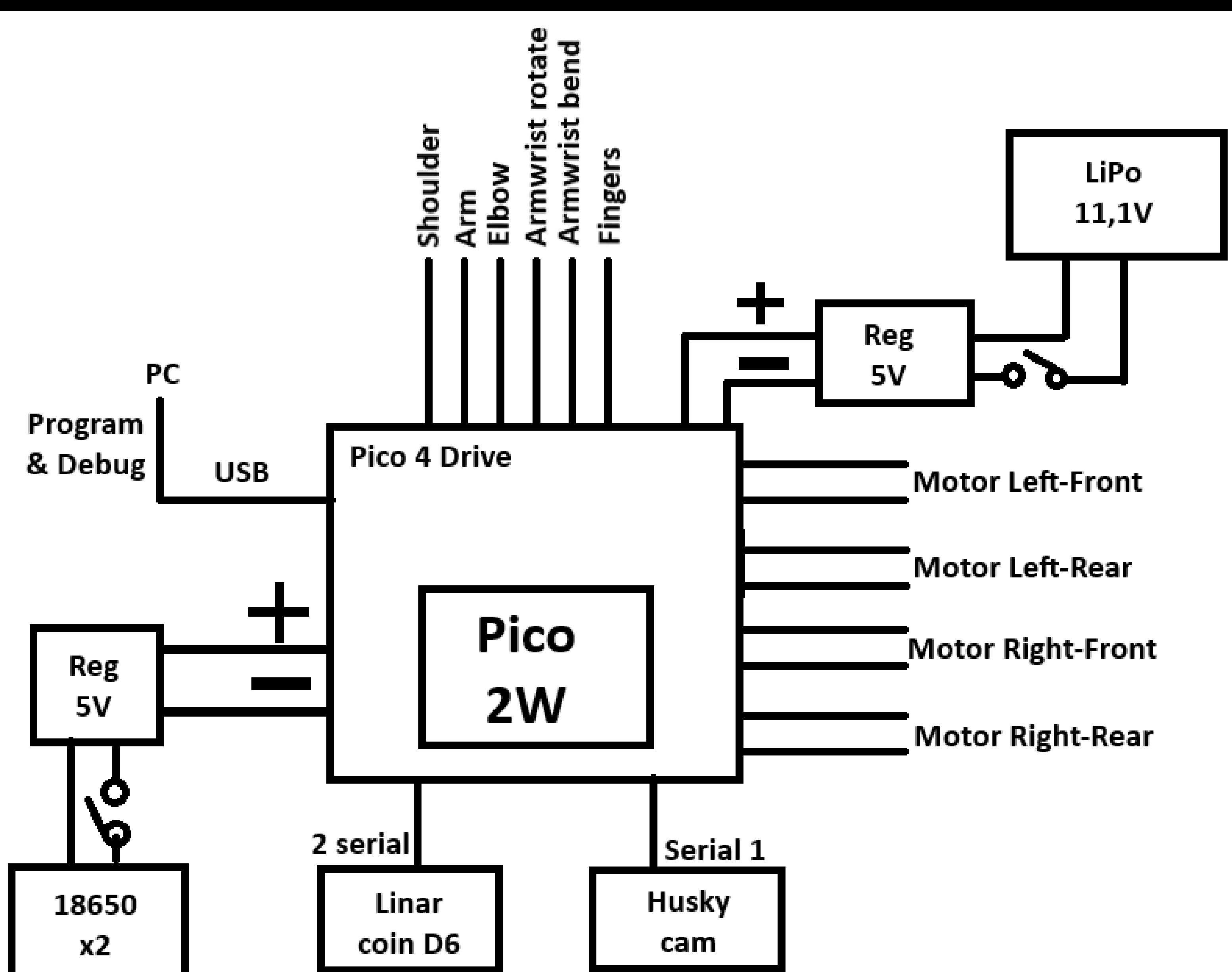

Part list

All three robots have:

PICO4DRIVE

control board with built-in motor controllers and ADC converter

PICO 2 W single-pin microcomputer

KCD11 switch

HuskyCam smart camera